

INCH-POUND

MIL-PRF-29504/5D
20 December 2006
SUPERSEDING
MIL-PRF-29504/5C
29 July 2004

PERFORMANCE SPECIFICATION SHEET

TERMINI, FIBER OPTIC, CONNECTOR, REMOVABLE, ENVIRONMENT RESISTING,
SOCKET TERMINUS, SIZE 16, REAR RELEASE, MIL-DTL-38999, SERIES III

This specification is approved for use by all Departments
and Agencies of the Department of Defense.

The requirements for acquiring the product described herein
shall consist of this specification and [MIL-PRF-29504](#).

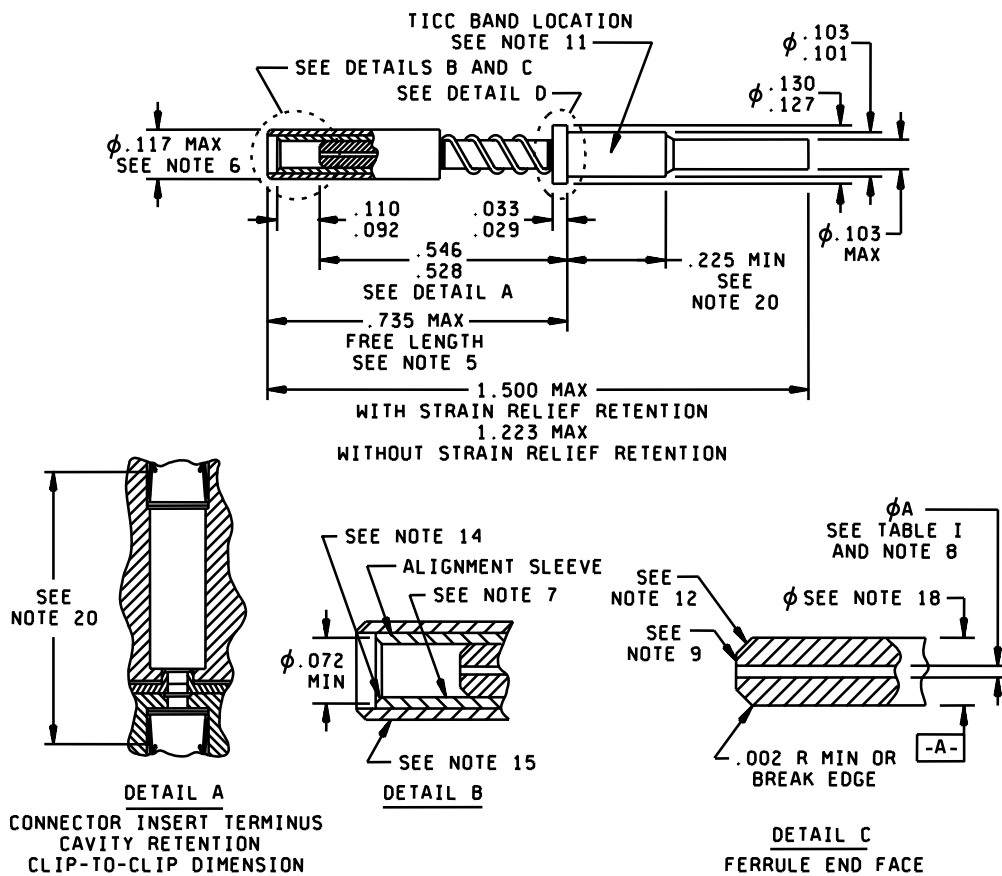
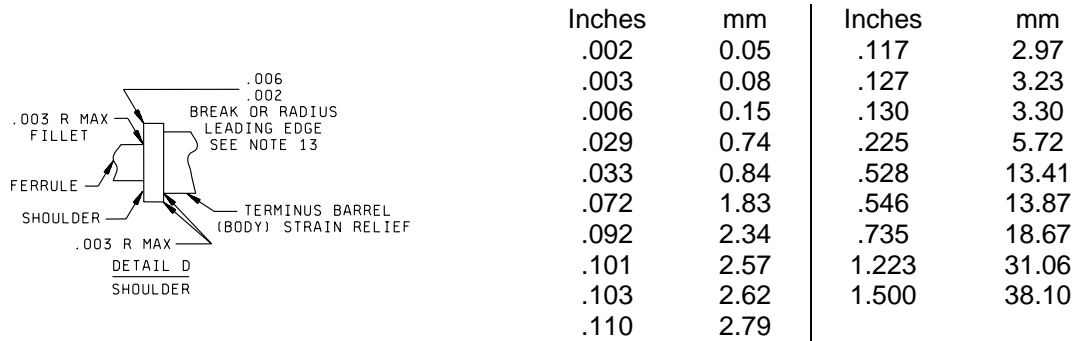

FIGURE 1. Socket terminus

MIL-PRF-29504/5D



NOTES:

1. Dimensions are in inches, except diameter "A" which is dimensioned in metric (microns).
2. Metric equivalents are given for general information only.
3. Unless otherwise indicated, all diameters are to be concentric with respect to datum A within .003 inch (0.08 mm).
4. Dimensions apply after plating when applicable.
5. Free length prior to installation in the connector.
6. Alignment sleeve and body design optional, not to exceed maximum envelope dimensions.
7. For alignment sleeve design, engagement force shall be less than preload force of the spring. For solid alignment sleeve design, the inside diameter (I.D.) shall be .06251 to .06270 inch (1.588 to 1.593 mm). For split alignment sleeve design, the (I.D.) tolerance does not apply.
8. Hole circular run-out in table I is relative to datum A.
9. Ferrule end face may be flat or have a radius that does not exceed a curvature of .39 inch (10 mm). Recommend inspection documentation advises that an end face curvature of .98 inch (25 mm) falls between that of a flat end face and one with a curvature of .39 inch (10 mm).
10. Hole "A" diameter and tolerance are specified in table I.
11. Manufacturer's symbol or trademark location is in front of the first TICC band (see figure 1 of MIL-PRF-29504). As an alternative to TICC bands, each digit of the TICC may be designated by the number which corresponds to the color band. An alternate location of the marking shall be allowed only in the case of insufficient surface area and only if approved by the qualifying activity.
12. Ferrule surface shown to have either a chamfer within 25° to 65° angle X .010 minimum or a .010 R minimum.
13. Optional dimension: Maximum allowable edge break is .015 inch (0.38 mm)
14. Alignment sleeve surface shown to be either .003 R minimum or chamfer within 25° to 65° angle X .003 minimum.
15. Alignment sleeve cover is optional for a non-ceramic alignment sleeve. For use with ceramic ferrules, ceramic alignment sleeves are preferred for new design.
16. Termini qualified to this specification sheet shall meet the performance requirements when inserted into a connector with clip-to-clip dimensions of .756 to .808 inch (19.20 to 20.52 mm).
17. Terminus design shall accommodate a single fiber cable with a maximum diameter of .087 inch (2.2 mm).
18. Ferrule diameter for ceramic: .06246 to .06250 inches (1.5865 to 1.5875 mm), ferrule diameter for metal: .06230 to .06248 inches (1.5824 to 1.5870 mm).
19. For interoperability with a standardized polishing puck, the length of exposed ferrule or the length of ferrule protrusion from the ferrule end face to the terminus first face of barrel (body) shall be .158 inches (4.01 mm) minimum.
20. Termini qualified to this specification sheet shall meet the performance requirements when inserted into a connector with clip-to-clip dimensions of .756 to .808 inch (19.20 to 20.52 mm).

FIGURE 1. Socket terminus - Continued.

MIL-PRF-29504/5D

21. For style 1 and 3 terminus only, reduction of the .225 inch (5.72 mm) minimum length to .025 inch (0.63 mm) is allowed. Additionally there shall be a smooth ramp transition on the terminus between the terminus barrel and the crimp sleeve/heat shrink so as not to restrict the function of the insertion and removal tool during the removal operation.
22. Terminus compression spring shall withstand an applied force of 8 pounds minimum with no damage.

FIGURE 1. Socket terminus - Continued.

Part or identifying number (PIN): See table II of this document and 6.6 of MIL-PRF-29504.

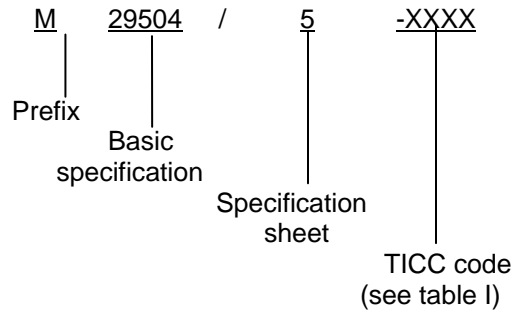

Usage: Termini compliant with this specification sheet are intended to be used in MIL-DTL-38999 connectors as applicable, and may be used in connectors other than MIL-DTL-38999 at the discretion of the acquiring activity. Termini compliant with this specification may not meet all requirements of MIL-DTL-38999 if not used in a series III connectors.

REQUIREMENTS:

Temperature ranges:

Operating: -67°F to 329°F (-55°C to +165°C)

Non-operating: -40°F to 185°F (-40°C to +85°C)

Storage: -40°F to 185°F (-40°C to +85°C)

Fabrication procedure. Standard fabrication procedure (for terminus placement/termination onto the end of an optical fiber), including epoxy specified in the procedure, shall be used for test sample terminations. Test sample configurations and fabrication shall be performed as specified in NAVSEA Drawing 8283255. A copy of this document can be obtained at Web Site: <https://fiberoptics.nswc.navy.mil/> in the NAVSEA Drawing section under Component Information.

Design and construction:

Dimensions and configuration: See figure 1 and table I. Pre-polished termini may have either flat or radiused end faces. Regardless of the end face geometry, the terminus shall meet the requirements of this specification when terminated using the procedures specified.

Weight: 1.0 gram maximum.

MIL-PRF-29504/5D

TABLE I. TICC numbers and "A" (ferrule hole) diameter for specified optical fiber sizes.

Fiber size (core/cladding) μm	Ferrule hole diameter μm	Ferrule material	Circular run-out μm	TICC style 1	TICC style 2	TICC style 3
Single mode < 9/125 <u>1/</u>	125 +1, -0	Ceramic	1 <u>2/</u>	4309	4312	4315
Single mode < 9/125 <u>1/</u>	125.5 +1, -0	Ceramic	1 <u>2/</u>	4310	4313	4316
Single mode < 9/125 <u>1/</u>	126 +1, -0	Ceramic	1 <u>2/</u>	4311	4314	4317
Single mode 9/125 <u>1/</u>	125 +1, -0	Ceramic	1 <u>2/</u>	4236	4246	4279
Single mode 9/125 <u>1/</u>	125.5 +1, -0	Ceramic	1 <u>2/</u>	4237	4247	4280
Single mode 9/125 <u>1/</u>	126 +1, -0	Ceramic	1 <u>2/</u>	4238	4248	4281
50/125, 62.5/125	126 +2, -0	Ceramic	2	4239	4249	4282
50/125, 62.5/125	127 +2, -0	Ceramic	2	4046	4250	4283
62.5/125/153	156 +3, -0	Ceramic	3	4240	4251	4284
62.5/125/155	157 +3, -0	Ceramic	3	4241	4252	4285
100/140	142 +3, -0	Ceramic	4	4049	4253	4286
100/140	145 +3, -0	Ceramic	4	4050	4254	4287
100/140/172	173 +1, -0	Ceramic	2	4296	4297	4298
100/140/172	173 +3, -0	Ceramic	4	4088	4255	4288
100/140/172	175 +3, -0	Ceramic	4	4242	4256	4289
200/230	236 +4, -0	Ceramic	8	4243	4257	4290
200/280	286 +4, -0	Ceramic	8	4244	4258	4291
400/440	448 +4, -0	Ceramic	8	4245	4259	4292
50/125, 62.5/125	127 +3, -0	Metal <u>3/</u>	3		4260	
62.5/125/155	157 +3, -0	Metal <u>3/</u>	3		4261	
100/140	142 +3, -0	Metal <u>3/</u>	4		4262	
100/140/172	175 +3, -0	Metal <u>3/</u>	4		4263	
200/230	236 +4, -0	Metal <u>3/</u>	8		4264	

1/ Applicable to any single mode core size. Also applicable to any multimode core size when enhanced performance is required and cladding tolerances permit.

2/ Circular run-out of 0.5 microns preferred, as it becomes more standard in industry.

3/ Termini with metal ferrules are intended primarily for legacy systems.

MIL-PRF-29504/5D

Cable strain relief capture mechanism. Three styles for a capture mechanism are specified for this terminus design (see table I). Cable strain relief capture mechanism shall not interfere with intended sealing performance of wire grommet seal, a component in the MIL-DTL-38999 connector, or with the functionality of the insertion and removal tools (see table II).

Style 1: Captive strength member outside barrel (body) with shrink sleeve.

Style 2: Captive strength member inside terminus barrel (body).

Style 3: Captive strength member outside terminus barrel (body) with crimp sleeve. The terminus shall meet all the requirements when the crimp sleeve is assembled to the terminus using a crimp die with flats measuring $.088 \pm .001$ inch ($2.235 \pm .025$ mm) across and .150 inch (3.81 mm) maximum long. The crimp die shall not contain an optional protrusion on either upper or lower die.

Tools: See table II.

TABLE II. Tools

Tool	PIN
Insertion tool	M81969/14-03
Removal tool	M81969/14-03

Mating terminus: MIL-PRF-29504/4.

Circular run-out: Not greater than the value specified in table I.

Frequency of terminus end face cleaning. Unless otherwise specified, terminus may be cleaned before or after each test if the connector is demated. Cleaning shall not be performed during the ten successive mates for the insertion loss test. Unless otherwise specified, cleaning may be performed during mating durability before each optical transmittance measurement. Terminus end face cleaning shall be performed for the post optical transmittance measurement after the salt spray test. The optical transmittance measurement is performed after the general cleaning and inspection for corrosion. Cleaning may be performed at other times when degradation in optical performance occurs. Cleaning performed as a corrective action for degraded optical performance shall be noted on the data sheet. Unless otherwise specified, cleaning of the optical end faces is to occur without removal of termini from the connector.

Qualification inspection. Inspections and sequence shall be performed as listed in table III.

MIL-PRF-29504/5D

TABLE III Qualification inspections.

Test procedure	Sample size
Unterminated termini	<u>1/</u>
Size	
Weight	
Identification markings	
Workmanship	
Circular run-out	
Terminus retention	
Terminus engagement and separation forces	
Terminus cleaning	
Termini as part of single fiber cable	<u>2/</u>
Cable pullout force	
Salt spray	
Termini in multiple termini connector	<u>3/</u>
Group 1	<u>4/</u>
Interoperability	<u>5/</u>
Insertion loss (initial)	
Return loss (single mode only)	
Group 2	<u>6/</u>
Mating durability	
Terminus cleaning	
Return loss (single mode only)	
Mechanical tests	
Shock	
Vibration	
Insertion loss (verification)	
Return loss (single mode only)	
Group 3	<u>6/</u>
Environmental tests	
Thermal shock	
Temperature life	
Insertion loss (verification)	
Return loss (single mode only)	

- 1/ Sample size shall be sufficient to ensure quantity of termini for inspections as part of a single fiber cable and inspections as an integral part of a multiple fiber connector.
- 2/ A minimum sample size of 16 socket termini shall be used. Cable pullout shall be performed on mating M29504/4 pin terminus only. Minimum of 16 socket termini shall be used for salt spray.
- 3/ Six (6) test samples (mated connector assemblies, fully populated with termini, consisting of MIL-DTL-38999 shell size 17 series III connectors with inserts containing 8 cavities) shall be used in accordance with test sample configuration in NAVSEA Drawing 8283255.
- 4/ Four (4) test samples from those in 3/ shall be used for group I inspections except for interoperability.
- 5/ Two (2) separately designated test samples (instead of 3/) shall be used for interoperability testing per NAVSEA drawing 8283255.
- 6/ Two (2) sets of test samples from group I (see 4/) shall be used for groups II and III testing.

MIL-PRF-29504/5D

Inspections for un-terminated termini:

Test sample configuration. Test fixture for this test shall include MIL-DTL-38999 shell size 11, 13, or 17, series III connectors, utilizing both plug and receptacle for retaining the termini during testing. A minimum sample size shall be used to ensure sufficient quantity for termini inspections as part of a single fiber cable and for termini inspections as an integral part of a multiple fiber connector.

Identification markings. The Termini Identification Color Coding (TICC) bands shall be marked on the barrel of the termini or use of the allowed alternative markings as stated in 11/ of figure 1. Manufacturer's symbol or trademark shall be in accordance with 11/ of figure 1. The manufacturer shall list the symbol or trademark with SAE in accordance with SAE AIR 1351.

Terminus retention. Terminus displacement measurement is not applicable. Test may be used as one operational means to verify acceptable shoulder construction.

Terminus engagement and separation force. Test is not applicable for socket terminus with solid alignment sleeves. For socket terminus with split alignment sleeves, maximum engagement force shall be 30 ounces (8.3 N) using a .0625 inch (1.588 mm) diameter gauge pin. The separation force is not applicable.

Maintenance aging. Not applicable.

Fungus resistance. Not applicable.

Inspections for the terminus as part of a single fiber cable:

Test sample configuration. Each terminus is to be terminated on one end of a single fiber cable. Cable used is to have provisions compatible with termini strain relief, as applicable. Termini, selected from the group that passed inspections for un-terminated termini (group 1), shall be used. A minimum sample size of 16 pin termini and 16 of the applicable counterpart socket termini, selected from the group that underwent inspections for un-terminated termini, shall be used.

Fiber pull out force. Not applicable (This test is used for terminus configurations with no type of cable strain relief).

Cable pull out force. Applicable for terminus configurations with any mechanism for cable strain relief. The change in optical transmittance shall be measured after the test for a socket terminus, during and after the test for a pin terminus.

Salt spray. Test samples (termini on single fiber cable) shall be tested to TIA/EIA-455-16, test condition C. Terminus ferrule may be covered up to half way from the end face to the shoulder with plastic protective (dust) covers. No corrosive effects shall be seen on the external connector parts that would be detrimental to the operation of the connector. No optical degradation shall occur as a result of this test. The criterion for insertion loss verification shall be used to determine if this optical requirement is met. Insertion loss verification, with termini inserted into a MIL-DTL-38999 shell size 17; series III connector, shall be performed both prior to and after the salt spray test.

MIL-PRF-29504/5D

Inspections for termini as an integral part of a multiple termini connector:

Test sample configuration: Four test samples (mated connector assemblies) shall be used for group I inspections except for interoperability. Two of these four mated connector assemblies shall be used for group II inspections and two for group III inspections. Each mated connector assembly shall be comprised of a cable assembly with termini placed into MIL-DTL-38999 shell size 17, series III connectors. These termini/connectors are located in the middle of the cable assembly. Termini, selected from the group that passed inspections for un-terminated termini, shall be used and inserted into MIL-DTL-38999 shell size 17 or higher, series III connectors as part of the cable assembly that comprises each test sample. Cable assembly length shall be 10 meters with the connector mated pair inserted 5 meters from the cable ends. Cable length may be longer (with added cable at the optical source end) if cut-backs are performed to verify insertion loss. Each connector shall be fully populated with termini. At least 8 randomly selected termini pairs in each cable assembly shall be monitored for optical transmittance after, and when specified, during environmental and mechanical testing. Insertion loss shall be performed on all termini pairs in each cable assembly. Connectors used in the cable assembly, both the plug and receptacle types, are to include backshells. Selection of the backshell is to include assurance of proper strain relief for each single fiber cable and not cause degradation in optical performance. Test sample configurations, fabrication methods and the specific test methods and practices shall be as specified in NAVSEA Drawing 8283255.

Interoperability. Applicable, except test for terminus insertion and removal forces is not required. Testing shall be performed using two separately designated cable assemblies with fully populated, MIL-DTL-38999, series III, shell size 17 connectors. Test performance and test sample configurations/fabrication shall conform to NAVSEA Drawing 8283255. As part of the interoperability inspection, terminus on the end of single fiber cable, shall be inserted and removed from the connector to verify that the strain relief is compatible with the tools listed in table II. At the discretion of the preparing activity, selected configurations may be specified to undergo inspections for shock, vibration, and mating durability. Interoperability is applicable only for termini among vendors with the same TICC such as fiber size, ferrule hole diameter, and ferrule material (see table I) with one addition. Termini shall be interoperable regardless of the style. Qualification by similarity will be given to a terminus in the same row in table I as the terminus tested for interoperability. This qualification by similarity is valid if the only difference between the terminus tested for interoperability and the terminus configuration in the same row in table I is a different cable strain relief capture mechanism and TICC markings.

Optical source wavelength. Termini with single mode fiber shall be tested using an optical source at the 1,310 nm wavelength. Termini with multimode fiber can be tested using an optical source at either the 850 nm or the 1,300 nm wavelength.

Launch conditions shall conform to NAVSEA Drawing 8283255:

Insertion loss. The initial insertion loss and the insertion loss verification for the various fiber sizes and ferrule materials shall be as specified in table IV. The insertion loss limits specified are the maximum allowed values for each measurement (each mating with respect to the pre-cut back measurement), not the average of the ten mating or other averaging schemes.

MIL-PRF-29504/5D

TABLE IV. Optical insertion loss performance. 1/

Fiber size (um)	Termini in non-tight tolerance M38999 <u>2/</u>		Termini in tight tolerance M38999/60 & M38999/61 <u>3/</u>		Ferrule material
	Initial insertion loss (dB)	Insertion loss verification (dB) <u>4/</u>	Initial insertion loss (dB)	Insertion loss verification (dB) <u>4/</u>	
Single mode < 9/125	1.25	1.75	1.25	1.75	Ceramic
Single mode 9/125	0.75	1.25	0.75	1.25	Ceramic
50/125	1.50	2.00	1.00	1.50	Ceramic
62.5/125	1.00	1.50	0.75	1.25	Ceramic
62.5/125/polyimide	1.50	2.00	1.00	1.50	Ceramic
100/140	0.75	1.25	0.75	1.25	Ceramic
100/140/polyimide	1.50	2.00	1.00	1.50	Ceramic
> 100/140	1.50	2.00	1.25	1.75	Ceramic
50/125	1.50	2.00	1.25	1.75	Metal
62.5/125	1.25	1.75	1.00	1.50	Metal
62.5/125/polyimide	1.50	2.00	1.25	1.75	Metal
100/140	1.25	2.25	1.00	1.50	Metal
100/140/polyimide	1.50	2.50	1.00	1.75	Metal
200/230	1.50	2.50	1.00	1.75	Metal

1/ Optical loss performance based on use of specified fabrication procedure.

2/ Termini in a MIL-DTL-38999 connector that is other than MIL-DTL-38999 tight tolerance series III connector (the latter being built to specification sheets MIL-DTL-38999/60 and MIL-DTL-38999/61 specific to fiber optic applications), the former distinguished from the tight tolerance type by denoting as the MIL-DTL-38999 non-tight tolerance connector.

3/ Termini in a MIL-DTL-38999 tight tolerance series III connector (the MIL-DTL-38999/60 and MIL-DTL-38999/61 specific to fiber optic applications) for shell sizes 9 through 19. For shell sizes 21 through 25, use performance requirements when termini are used in a MIL-DTL-38999 non-tight tolerance connector.

4/ Insertion loss verification is an insertion loss performed after a series of environmental tests or mechanical tests.

Mechanical. The following mechanical tests shall be performed in the sequence listed following the post mating durability, return loss test: mechanical shock, vibration. For single mode termini, a discontinuity is considered to be a reduction of optical transmittance of 0.5 dB or more for a duration of 50 microseconds or more (during vibration) or 100 milliseconds or more (during shock).

Mechanical shock. Mated connector assemblies shall be tested in accordance with the applicable mechanical shock test listed below. Optical discontinuities shall be measured during the test. For connectors of shell sizes 17 and greater, a minimum of four termini shall be monitored for discontinuity. The change in optical transmittance shall be monitored after the test. The termini shall be visually examined after the test to the extent feasible inside the connector. Termini shall not be damaged and there shall be no loosening of parts. The requirement for optical discontinuity shall be met during the test and the requirement for the change in optical transmittance shall be met after the test. For testing, initially mate the connector assemblies and apply the specified torque value. Mark the position after the torque has been applied and check/record position after each impact. For a mating connector containing a coupling ring ratchet mechanism, do not tighten the coupling ring after each impact if the connector is being tested in addition to the terminus. Otherwise, retighten after each impact.

MIL-PRF-29504/5D

- a. MIL-S-901. Mated connector assemblies shall be tested in accordance with MIL-S-901, grade A, type B, class I. Standard shock fixture 4A for bulkhead mounting shall be used. Supplement test fixture with mounting shall be performed as specified in NAVSEA Drawing 8283255.”
- b. Half-sine pulse. Mated connector assemblies shall be tested in accordance with TIA-455-14, test condition D. Three shocks in each direction shall be applied along the three mutually perpendicular axes of the test sample (18 shocks).

Vibration. Mated connector assemblies shall be tested for sinusoidal vibration in accordance with the applicable vibration tests listed below. Optical discontinuities shall be measured during the test. For connectors of shell sizes 17 and greater, a minimum of four termini shall be monitored for discontinuity. The change in optical transmittance shall be monitored after the test. The termini shall be visually examined after the test to the extent feasible inside the connector. Termini shall not be damaged, and there shall be no loosening of parts, no backing off of the coupling mechanism, and no other damage which can produce physical distortion or wear and may result in fatigue of the mechanical parts. The requirement for optical discontinuity shall be met during the test and the requirement for the change in optical transmittance shall be met after the test. For testing, initially mate the connector assemblies and apply the specified torque value. Mark the position after the torque has been applied and check/record position after each axis. For a mating connector containing a coupling ring ratchet mechanism, do not tighten the coupling ring during testing.

Sine vibration in accordance with 4.5.22.2.1 of MIL-DTL-38999 (60 G at ambient temperature only). This cycle shall be performed 12 times in each of three mutually perpendicular directions at ambient temperature. This results in a total of 36 cycles being applied for approximately 12 hours. The sequence shall be repeated twice. (36 hours total at ambient temperature). Interruptions are permitted provided the requirements for rate of change and test duration are met. Completion of cycling within any separate band is permissible before proceeding to the next band.

Random vibration in accordance with 4.5.22.2.3 of MIL-DTL-38999 (41.7 G rms at temperature of 125°C).

Random vibration in accordance with 4.5.22.2.4 of MIL-DTL-38999 (49.5 G rms at ambient temperature)

Environmental. The following environmental tests shall be performed in the sequence listed: Thermal shock and temperature life.

Thermal shock. The temperatures of -55°C +0°C, -5°C and +165°C +5°C, -0°C shall be used for the low and high soak temperatures, respectively. Mated connector assemblies shall be tested in accordance with TIA/EIA-455-71, schedule C-0 (5 cycles). The mated connector assemblies shall not be un-mated then re-mated after the test as part of the inspection. The change in optical transmittance shall be measured during (towards the end of each soak temperature) and after the test. The termini shall be visually examined after the test only if optical performance is not met. Termini shall not be damaged, and there shall be no loosening of parts, separation of bonded surfaces or other damage detrimental to the operation of the termini. The requirement for the change in optical transmittance shall be met during and after the test.

MIL-PRF-29504/5D

Temperature life. The high exposure temperature shall be 165°C +5°C, -0°C. Mated connector assemblies shall be tested in accordance with TIA/EIA-455-4 for the duration of 1,000 hours at the high exposure temperature. The change in optical transmittance shall be measured after the test. The termini shall be visually examined after the test to the extent feasible inside the connector. Termini shall not be damaged, and there shall be no loosening of parts, separation of bonded surfaces or other damage detrimental to the operation of the termini. The requirement for the change in optical transmittance shall be met after the test. Performance of a cable/fiber retention test is not required as part of the final inspection for this test.

Insertion loss verification: If the cut back method is used after the mechanical or environmental tests are concluded, then the return loss may be performed prior to the insertion loss verification.

Qualification connector: The qualification connector for this termini shall be a qualified MIL-DTL-38999 connector.

Qualification by similarity.

a. Qualification of termini for single mode fiber sizes.

- (1) Qualification inspection shall be performed on termini with a ferrule hole diameter of 126 microns when termini with both 125 (or 125.5) and the 126 micron ferrule hole diameters are offered. Manufacturers who qualify under this specification sheet for the 126 micron ferrule hole diameter are qualified under this specification sheet for the 125 or 125.5 micron ferrule diameter. Qualification inspection shall be performed on the 5.8/125 micron fiber size.
- (2) Constraint for qualification by similarity case listed above. This qualification by similarity case is valid if the only difference between the qualified termini (single mode 126 micron) and the smaller size termini is a change in the terminus ferrule hole diameter and TICC markings.

b. Qualification of termini for multimode fiber sizes.

- (1) Complete qualification inspection shall be performed on termini with optical fiber having a cladding diameter of 125 microns. Termini shall have a ferrule hole diameter of 126 +1, -0 microns. Manufacturers who qualify under this specification sheet for the terminus with the 126 +1, -0 micron ferrule hole diameter are qualified under this specification sheet for the other 125 cladding hole diameters for use with multimode fiber sizes. Manufacturers who qualify under this specification sheet for the terminus with the 126 +1, -0 micron ferrule hole diameter are qualified under this specification sheet for the other (in this case, polyimide) hole diameters for use with multimode 50/125 or 62.5/125 micron fiber sizes.
- (2) 100/140 fiber size. Manufacturers who qualify under this specification sheet for the termini with the multimode, 50/125 or 62.5/125 micron fiber size and pass the insertion loss and size inspections are qualified under this specification sheet for the 100/140 micron fiber size. Qualification inspection for the 100/140 micron fiber size shall be performed on termini with a ferrule hole diameter of 173 +3, -0 microns to cover the case for terminations of termini onto polyimide coated fiber. Manufacturers who qualify under this specification sheet for the terminus with the 173 +3, -0 micron ferrule hole diameter are qualified under this specification sheet for the other 100/140 hole diameters for use with multimode fiber sizes (both non-polyimide and polyimide).

MIL-PRF-29504/5D

- (3) Multiple fiber sizes, same ferrule hole diameter. Manufacturers who qualify under this specification sheet for termini with the 50/125 micron fiber size are qualified under this specification sheet for the 62.5/125 micron fiber size. Qualification inspection shall be performed on termini with a ferrule hole diameter of 126 +1, -0 microns.
 - (4) Sizes larger than 100/140 fiber. Manufacturers who qualify under this specification sheet for the termini with the multimode, 100/140 micron fiber size or less are qualified under this specification sheet for the termini with larger fiber sizes.
 - (5) Metal ferrule sizes. Manufacturers who qualify under this specification sheet for the termini single mode and for multimode fiber sizes with ceramic ferrules and perform the full qualification inspection for the 100/140/172 fiber size using a 175 +3, -0 ferrule hole diameter and the size and insertion loss inspections for the 62.5/125/155 fiber size using the 157 +3, -0 ferrule hole diameter are qualified under this specification sheet for the other ferrule hole diameters with multimode fiber.
 - (6) Constraint for qualification by similarity cases listed above. These qualification by similarity cases are valid if the only difference between the qualified termini and the larger size termini being offered is a change in the terminus ferrule hole diameter and TICC markings.
- c. Qualification of termini for different cable strain relief capture mechanisms.
- (1) Qualification inspection shall be performed on termini for the smallest fiber size and with the largest hole diameter being offered.
 - (2) Manufacturers who qualify under this specification sheet for termini with one style of cable strain relief capture mechanism and pass the insertion loss, cable pullout, thermal shock, temperature life and the insertion and removal force verification are qualified under this specification sheet for a different cable strain relief capture mechanism. Insertion and removal force verification of the termini to and from the connector shall be performed, with the termini on the ends of single fiber cable, to verify that strain relief is compatible with tools in table II.
 - (3) Constraint for qualification by similarity case listed above. This qualification by similarity case is valid if the only difference between the qualified termini and the termini undergoing qualification is a different cable strain relief capture mechanism and TICC markings.
- e. Qualification of termini for change in design and/or material.
- (1) Perform complete re-qualification.

Cleaning prior to packaging. Termini shall be cleaned prior to packaging/shipment internally (for ensuring proper adherence of epoxy to terminus barrel (body) and ferrule and externally (for minimizing contamination).

MIL-PRF-29504/5D

Referenced documents. In addition to MIL-PRF-29504, this specification references the following:

MIL-PRF-29504/4	MIL-S-901	TIA-455-14
MIL-DTL-38999	NAVSEA drawing 8283255	TIA/EIA-455-16
MIL-DTL-38999/60	SAE AIR 1351	TIA/EIA-455-71
MIL-DTL-38999/61	TIA/EIA-455-4	

Marginal notations are not used in this revision to identify changes with respect to the previous issue due to the extent of the changes.

Custodians:

Army - CR
Navy - SH
Air Force - 11
DLA - CC

Preparing activity:

DLA - CC

(Project 6060-2006-020)

Review activities:

Navy - AS
Air Force - 13, 19, 93, 99
NASA - NA

NOTE: The activities listed above were interested in this document as of the date of this document. Since organizations and responsibilities can change, you should verify the currency of the information above using the ASSIST Online database at <http://assist.daps.dla.mil>.